



CAN Tilt Tilt Sensor

Product Highlights

- Dual Axis Tilt measurement over CAN
- Factory Configurable for multiple nodes and speeds
- Easy Installation
- IP67

General Features



- No moving parts
- Fully protected (reverse supply, output s/c, etc)
- Connectors used on module are 2 x Deutsch DTF13-4P

Technical Data

Tilt range	- 20° - +20°	In x and y axis
Resolution	Better than 0.2°	Message increments by 0.1°
Repeatability	0.2°	limited by Resolution
Response time	100ms max.	
Supply Voltage (reverse protected)	8.5 – 60Volts DC	
Supply Current	20mA max.	
Output Current	2mA	
Operating temperature	-40 – +70 °C	
Storage Temperature	-40 – +85 °C	
Water proof	IP 67	

Dimensions [mm]

- Pin 1 – GND
- Pin 2 - Can L
- Pin 3 - Can H
- Pin 4 - Supply

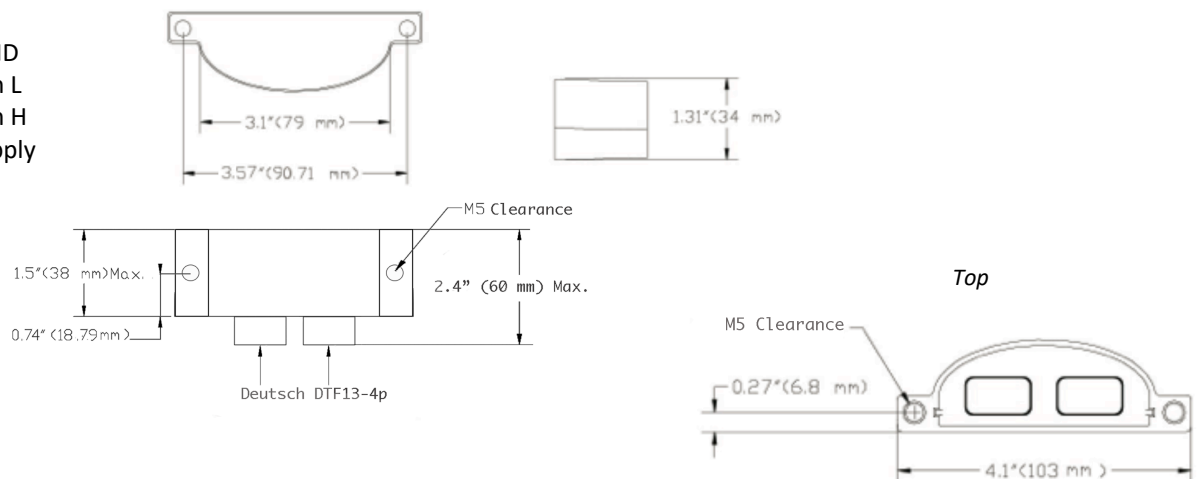

Note: Maximum torque to apply to the M5 fixing screws, not to exceed 1Nm.



Mounting Instructions

- The module should be installed as pictured

Standard CAN Tilt CAN Message Format

Repeatedly transmits tilt message every 50-60ms

ID = 15X (150 + Node ID set in data flash, default 151)

byte

0	X angle high byte, signed
1	X angle low byte, signed
2	Y angle high byte, signed
3	Y angle low byte, signed
4	0 (Unused)
5	0 (Unused)
6	Software version
7	Error state

Example:

151 00 2A FF F0 00 00 02 01

X angle 2A (4.2 degrees), Y angle FFF0 (-1.6 degrees), SW vers 2, no error

Note: Custom messaging, CANopen-compatible, and J1939 implementation on request.

